

## ER20

### CAT50 & Straight Shank ER20 Collet Chucks

(Balanced to G2.5@15,000 RPM)



- Small diameter nose well-suited for working in close quarters
- Increased flexibility for milling, drilling, and reaming
- Flush precision collet nut, grips tool close to cutting edge for accuracy and rigidity
- Concentric to .0002" TIR puts tool precisely on spindle center line
- AT3 or better shank taper allows for accurate, rigid toolholder-to-spindle mount
- Wide range collets reduce collet and toolholder inventories
- Fully ground flange and V-groove is easy on tool changers for less spindle and changer maintenance
- Through spindle coolant standard
- [ER20 Collets found on pages 604-605.](#)

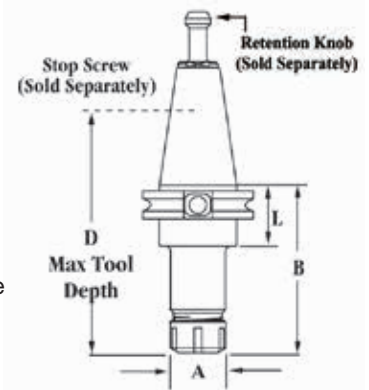

### CAT50 ER20 Collet Chucks

Capacity	Taper	A	Gage Length (B)	D	L	Max. Nosepiece Torque	Part #
.040-.511	CAT50	1.38	4.00	3.50	1.38	36 ft lbs	<a href="#">RC5ER204000</a>
.040-.511	CAT50	1.38	6.00	3.50	1.38	36 ft lbs	<a href="#">RC5ER206000</a>
.040-.511	CAT50	1.38	8.00	3.50	1.38	36 ft lbs	<a href="#">RC5ER208000</a>

### ER20 Straight Shank Collet Extension

A	B	D	L	Photo	Dimensions	Part #
1.38	7.0	1.00	5.8			<a href="#">RSSER20700</a>

### ER20 Parts & Accessories

Description	Photo	Dimensions	Part #
ER20 Replacement Nosepiece			<a href="#">RER20NPA</a>
ER20 Collet Wrench†			<a href="#">RER20W</a>
ER20 Stop Screw			<a href="#">RER20SS</a>
ER20 Stop Screw Coolant Thru			<a href="#">RER20SSC</a>

†Required for assembly.